

BOXIDZER RTO



by

Alliance Corporation

- 98% VOC design destruction efficiency, 95% guaranteed
- 95% thermal efficiency
- **Completely fits inside 20' ISO container**
- Flow range 1400 to 5600 NM³H / 800 to 3300 SCFM
- Skid mounted ● Factory preassembled
- Digital burner air/fuel gas ratio control
- Field selectable fuel gas type
- 250 kWh @ 100 mBAR / 0.7 mmBTUH @ 1.5 PSI single fuel gas point of connection
- Completely prewired at factory

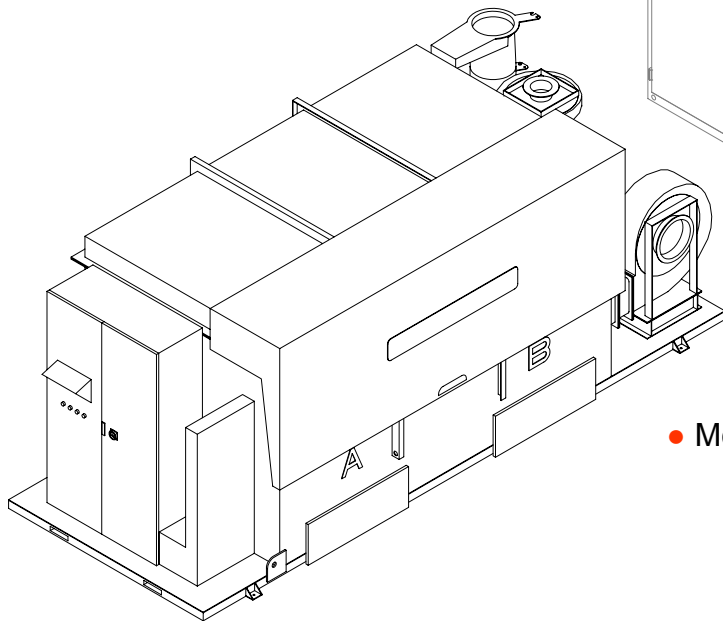
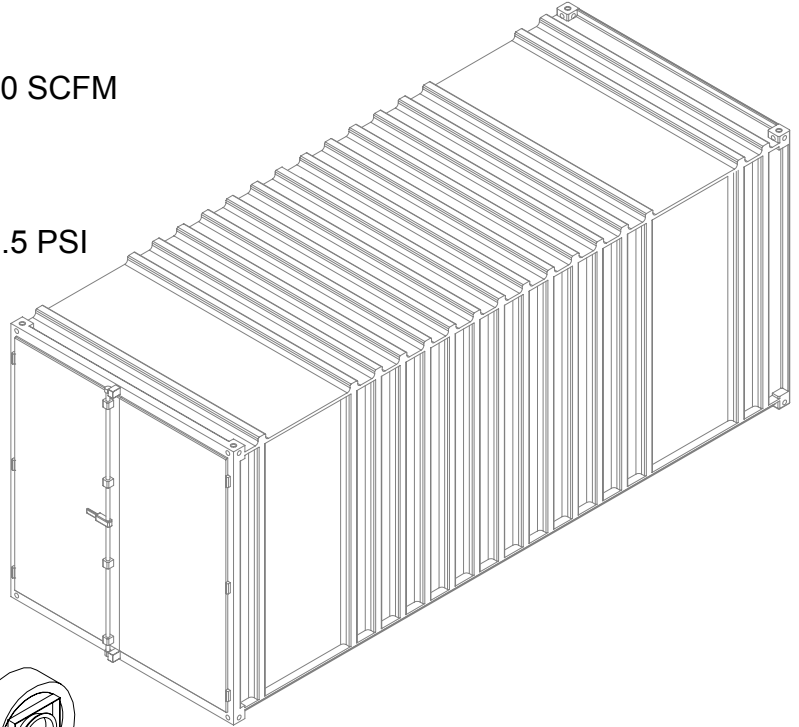

- 380 to 480 VAC
- 50 to 60 hZ, 3 phase, 15 kVA single electric point of connection
- Variable Frequency Drives on ALL motors ● Vacuum/flow control
- Modem ● Telemetry data logging ● Self calibrating
- 0.2 NM³H @ 5.5 BAR / 8 SCFH @ 80 PSI single pneumatic point of connection
- 5.715M x 2.134M / 18'-9" x 7'-0" footprint
- 10200 kG / 22400 lb approx. weight

- **Factory assembled** ● **Easy shipping**
- **Simple installation** ● **Quick startup**

